

**Sollevatori fissi**  
**Fixed Pool Lifts**

# F100 M / F100



**SOLLEVATORI FISSI / FIXED POOL LIFTS**

## Sollevatore fisso **F100 M / F100**

Il sollevatore fisso **F100 M / F100** permette, attraverso la sua struttura solida e rotante, di far entrare la persona disabile in acqua in piscine fuori terra rialzate in tela, plastica, legno: è indicato per le piscine esterne. L'ancoraggio deve sempre avvenire su cemento armato mediante 8 tasselli o plinto di cemento di dimensioni 60x60x60 cm.

## Fixed Pool Lift **F100 M / F100**

The **F100 M / F100** poolside hoist is to be used at walled pools either in plastic or wood. It enables the disabled person to get into the water in a safe and smooth way. It is recommended for outdoor pools. The anchorage is always to be made to a concrete block of 60x60x60 cm by means of 8 pins.

# Sollevatori fissi **F100 M / F100** Fixed Pool Lifts

### Certificazioni e brevetto

- Direttiva 93/42/CEE - Dispositivi Medici - DM 321258/R - DM943674/R
- Direttiva 2006/42/CE - Direttiva Macchine
- Direttiva 2004/108/CE - EMC Compatibilità Elettromagnetica

### Certifications and Patent

- Directive 93/42/EEC - Medical Devices - DM 321258/R - DM943674/R
- Directive 2006/42/EC - Machinery Directive
- Directive 2004/108/EC - EMC Electromagnetic Compatibility

**F100 M**



**F100**

**SOLLEVATORI FISSI / FIXED POOL LIFTS**



### Ingombri Measurements

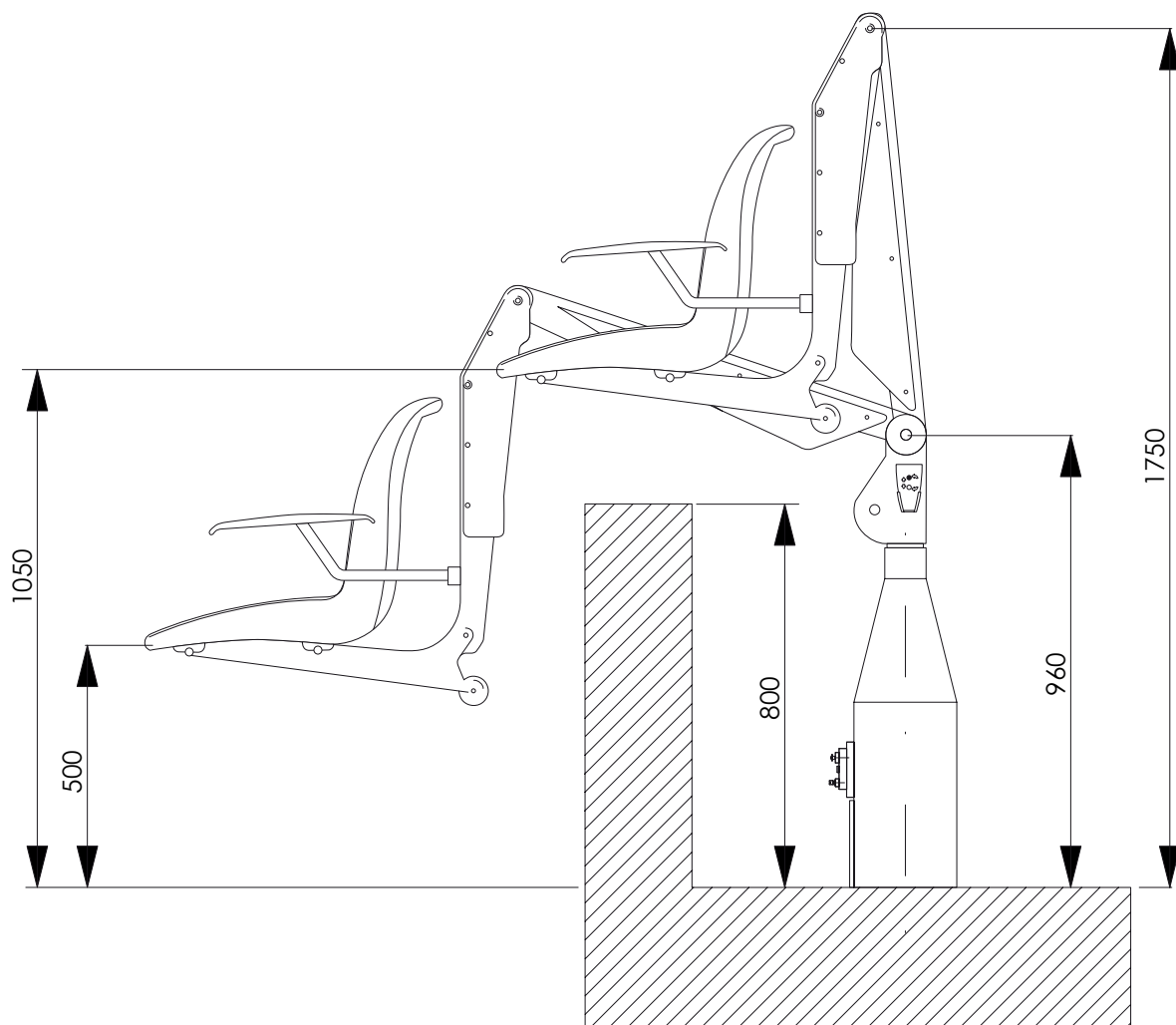

### Dati/Materiali/Dotazioni

Portata massima	140 kg
Corsa max (senza supporto)+1150 mm -250 mm	
Tempo discesa in acqua con carico	23 sec
Tempo di risalita dall'acqua con carico	17 sec
Peso in ordine di lavoro	100 kg
Batteria	24 V
Tensione	12 V
Centralina elettroidraulica	
Caricabatterie esterno	
Rotazione	350°
Struttura in acciaio con trattamento di zincatura e verniciatura a polvere	
TELECOMANDO	

### Features/Materials/Equipment

Maximum capacity	140 kg
Maximum travel (without support) +1150 mm -250 mm	
Time of down-lifting with weight	23 s
Time of up-lifting with weight	17 s
Total weight	100 kg
Battery	24 V
Power	12 V
Electrohydraulic box	
External battery charger	
Rotation	350°
Structure in steel: zinc coated and powder finished	
REMOTE CONTROL	